



# SOLIDCOR<sup>30</sup> R30 Fire Door System



**Sovereign**  
GROUP LIMITED

[sov-group.co.uk](http://sov-group.co.uk)

# Fire Door System

---

The Solidcor R30 Fire Door System results from a journey of listening. A journey that started by listening to the wish-list of a highly respected London Housing Association with a 40,000 plus property portfolio.

Architect led, the Housing Association asked for a fire rated doorset designed to assist the less able. The system must be low maintenance due to limited budget, and returning to the days of decorating costs associated with painted doors and frames was not an option. This wish-list is now reality with the R30 Fire Door System.

The Solidcor R30 System has been put through rigorous testing to ensure a safe product with successful bi-directional EN 1634 testing, PAS 24, Smoke Leakage, Weather and Endurance testing. (see page 3)

Tested to the highest standards for the following Third Party Certification, Secured by Design and CE Marking. Designed through listening.



**SOLIDCOR<sup>30</sup>**

**SAFE TODAY SAFE TOMORROW**

t. 01282 618171 | e. info@sov-group.co.uk

**sov-group.co.uk**



**Sovereign**  
GROUP LIMITED

# Fire Door Styles



**ASHOVER**

4 Panel Half Moon IGNIS  
Glazing



**BRAMPTON**

Solid Panel  
Flat grain



**BRAMPTON I**

Solid Panel with Diamond  
IGNIS Glazing 190 x 190mm

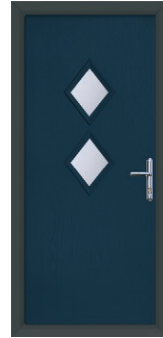

**BRAMPTON II**

Solid Panel with  
2 x Diamond IGNIS  
Glazing 190 x 190mm



**MATLOCK**

2 Panel with  
2 x IGNIS Half Panel  
Glazing 203 x 914mm



**CURBAR**

Solid Panel  
Flat grain



**CURBAR I**

Solid Panel with Diamond  
IGNIS Glazing 190 x 190mm



**CURBAR II**

Solid Panel with  
2 x Diamond IGNIS  
Glazing 190 x 190mm



**DARLEY**

2 Panel Half IGNIS  
Glaze 558 x 914mm



**STANTON**

6 Panel Plain Door



**STANTON II**

6 Panel with  
2 x Small IGNIS  
Glazing 203 x 152mm



**TOP LIGHT**



**SIDE LIGHT**

**SOLIDCOR<sup>30</sup>**

SAFE TODAY SAFE TOMORROW

t. 01282 618171 | e. info@sov-group.co.uk

**sov-group.co.uk**



**Sovereign**

GROUP LIMITED

# Compliance Fire Testing & Performance Testing

**R30 Fire Door System is independently and successfully tested by UKAS accredited bodies to the following standards:**

- Dual Certification – Doorsets certificated and supplied to the same specification for fire, smoke and security performance
- Complete Doorset "supplied complete with all essential parts from a single source..." as defined in BS EN 12519
- EN 1634-1 Fire tested bi-directionally – as required in Building Regs Approved Doc B (ADB)
- Third-party Certification for Fire & Smoke
- ISO 9001 & Factory Production Control System
- Traceability back to one source
- EN 1634-3 Smoke Tested
- PAS 24:2016 Security Tested & Dual Certified – required in Approved Document Q (ADQ) for Security in Dwellings
- Secured by Design accredited
- BS 6375-2 Mechanical strength tested including soft & heavy body impact, hard body impact, load bearing
- BS EN 1191 & BS EN 12046-1 tested to resistance to repeated opening & closing
- BS 6375-1 Weathertightness tested in accord with BS EN 1027:2000
- BS 6375-1 Air permeability tested in accord with BS EN 1026:2016
- BS 6375-1 Resistance to wind load in accordance with BS EN 12211:2016
- EN ISO 10077 Choice of U-Rating from 1.3, 1.8 and 2.0 W/m<sup>2</sup>K – as required in Building Regs approved document L (ADL)
- Assists BS 8300 (formerly DDA) accessibility as defined in the Equalities Act – as required in Building Regs approved document M (ADM)

## Patent Pending Frame Technology

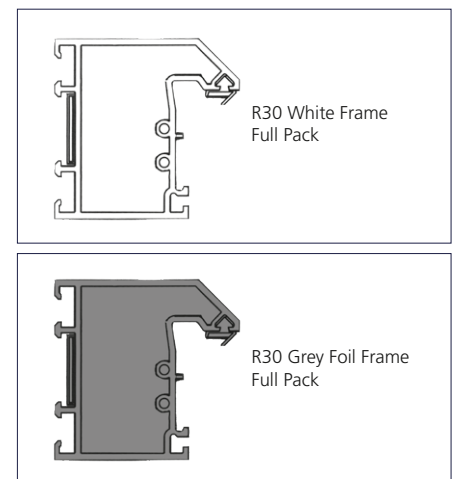
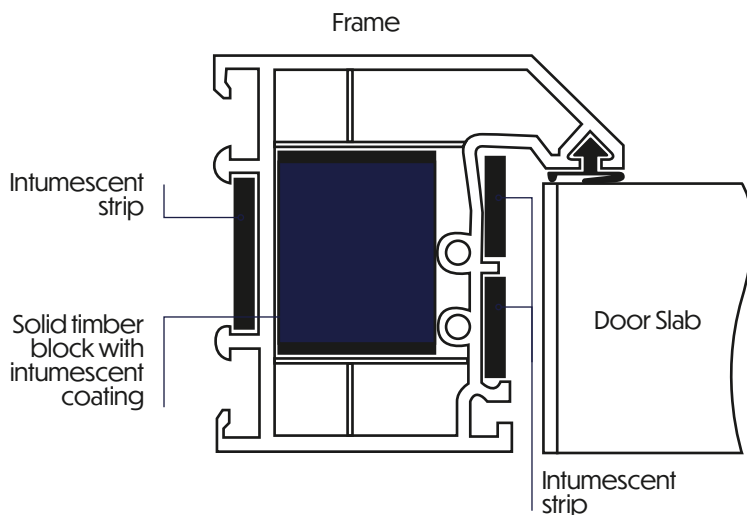

- Highly durable against weather, vandalism and crime
- 10 year guarantee on the frame and slab

- 5 year guarantee on the hardware
- Solid timber core door leaf and frame for consistent fire protection



**SOLIDCOR<sup>30</sup>**

**SAFE TODAY SAFE TOMORROW**

t. 01282 618171 | e. info@sov-group.co.uk

**sov-group.co.uk**



**Sovereign**  
GROUP LIMITED

# Why this System?

---

- ✓ Consistent solid core giving:
  - Consistent burn performance
  - Consistent security performance
- ✓ Maintenance free
- ✓ Can be glazed
- ✓ Letter box option
- ✓ Large size variation

**SOLIDCOR<sup>30</sup>**

SAFE TODAY SAFE TOMORROW

t. 01282 618171 | e. info@sov-group.co.uk

**sov-group.co.uk**



**Sovereign**  
GROUP LIMITED

# Golden Thread of Accountability

Solidcor's golden thread of traceability underpins the mission of 'safe today, safe tomorrow' with clear accountability from component creation to final installation and ongoing maintenance.

## Components

Solidcor manufacture and supply all components, every stage of production audited by UKAS accredited certification bodies.



## Door Data Systems Tag

The door's unique data tag, enables critical information regarding the door to be stored and easily accessed, providing an easy to use system for manufacturers, installers, inspectors, maintenance engineers, building owners and managers.

Fitting the data tag on all our doors supports the call for door information to be made available to all, helping to ensure compliance through the door lifecycle.

**SCAN THE TAG USING THE FREE APP (Door Data Systems).**



## Licensed Fabricator

Solidcor licensed fabricator will create doorset, following strict accredited guidelines. The doorset will be checked and certified then the door safety data APP up-loaded with the manufacturer's details, certification and test data before delivery to site.



## UKAS Accredited Installer

Once the completed doorset is delivered to site, an accredited UKAS installer will ensure the doorset is installed on site following all current guidelines.

During the installation, images, compliance questionnaire and sign off along with the company and fitters credentials can all be uploaded effortlessly. Recording a managed compliant installation and providing the installation company with evidence of works undertaken.



## Third Party Certified

After the door has been successfully installed, the data tag and system can be utilised to support ongoing compliance inspections, by scanning the tag, the qualified inspector records via the mobile app a full industry inspection, adding photos in-turn creating reports enabling facility managers to view the status of their buildings via the management dashboard.



## Ongoing Maintenance

Engineers assigned repairs can easily access part listings, record the repair, complete a sign off and move on the status of the door. At the same time the facility management will see the ageing of outstanding works enabling a focused approach in achieving compliance.



**SOLIDCOR<sup>30</sup>**

SAFE TODAY SAFE TOMORROW

t. 01282 618171 | e. info@sov-group.co.uk

**sov-group.co.uk**



**Sovereign**

GROUP LIMITED



**SOLIDCOR**  
SAFE TODAY SAFE TOMORROW

**Solidcor**  
Whittington Way  
Chesterfield, S41 9AG

t. +44 (0)1246 264245  
e. sales@solidcor.co.uk

**solidcor.co.uk**

**Sovereign**  
GROUP LIMITED

**Sovereign Group Ltd,**  
Vale Street  
Nelson  
Lancashire, BB9 0TA

t. 01282 618171  
e. info@sov-group.co.uk

**sov-group.co.uk**